



Instrument Solutions for

Lawn and Garden
Off Road
Industries



With some of the most sophisticated information and instrumentation systems in the industry, and a range of products that are rugged enough to survive on military Humvee and heavy construction equipment, or with innovative styling for your boat or RV, Faria/Beede Instruments have the right products to meet future global needs for rugged, reliable, and innovative instrumentation.

An ISO9001-2008 Registered Company

Rugged • Reliable • Innovative

For more than 100 years Faria Beede has been dedicated to the principle of supplying our customers with the highest quality product at the most competitive prices.

All Faria Beede instruments are performance proven under the most demanding conditions. They are factory installed original equipment with major manufacturers worldwide. You can rely on Faria Beede Instruments, Inc. for world class quality, dependability and ease of installation.

Our years of manufacturing experience and knowledge of the industries we sell to have taught us to listen to the market place. Our in-house product design and development, component manufacture and instrument assembly allow us to respond quickly to your needs.

The company-wide use of Statistical Process Control (SPC), not only for ourselves but by our vendors as well, allow us to maintain a consistently high standard. In 1998, our efforts were recognized by the world as we became an ISO9001 registered company. We continually reaffirm our commitment to this standard and are now registered as a ISO9001:2008 company.

With the recent purchase of Beede Instruments of Penacook, NH, Faria has expanded our manufacturing capabilities to offer a broader product offering, unsurpassed value and design for all of our markets, including the US Military, industrial, recreational and majority of the world's leading boat manufacturers.

We support our products with a comprehensive Limited Warranty. Should you need them, our dedicated Customer Service Technical Experts are ready to provide installation, troubleshooting and warranty assistance.

Instruments for
Automotive
Commercial
Industrial
Performance
Recreational
Marine
Military

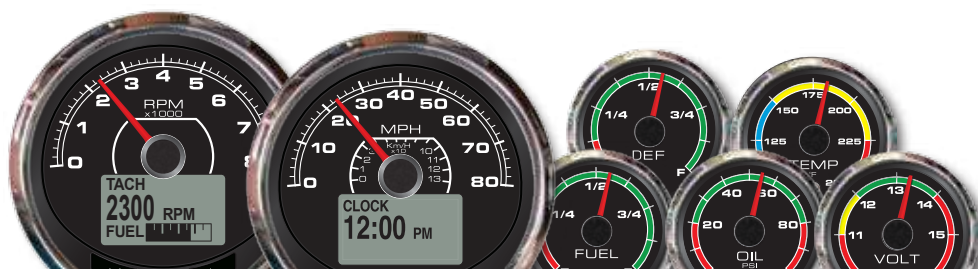

 Made in the USA

Small Engine and Lawn Care equipment manufacturers

SAE J1939

A complete engine monitoring solution for the small engine CAN bus market.

This compact instrument provides a single source view of the critical information provided by the engine ECU. The CAN display instrument is designed to read and process SAE J1939 compliant CAN messages. The large sunlight readable, transreflective LCD displays operating parameters with easy to read characters. The "second line" data displays a continual readout of the engine's hours or "over the road" Odometer.

Up to 12 display pages can display the information being sent by the engine ECU, including Trip data and advanced Fuel Management. Should a DM1 or J1939 alarm occur the J1939 CAN display will activate a 13th display screen for the operator to log the alarm, while maintaining the regular data screens.

An audible beep will sound when a CAN error message is initiated from the ECU and the LCD will flash warning the operator of a fault or alarm. This alarm may be silenced temporarily by the user. A full list of faults is stored locally on the device.

On board programmable parameters allow for customizing of menu options including, Max Speed, Audio, Fuel Tank, Units and Master Program Reset (Return to factory settings).

Available Display Functions

Voltage	Speed Over Ground	Trip Data (Re-settable)
Engine Boost	Engine Speed	Engine Hours
Engine Load	Transmission Pressure	000012.5
Engine Coolant Temp.	Transmission Temp.	Fuel Used
Fuel Level, Tank 1	Fuel Instantaneous	Odometer
DEF Level		Fuel Rate
Oil Pressure		

All screens can be customized for OEM volume orders.

Fits a typical round 2 1/16" (53mm) panel hole.



Shown actual size

J1939 FAULT
SPN XXXXX
FMI XX
CT XX

Features and Benefits

- SAE J-1939 CAN protocol support
- Nylon cases for corrosion resistance and long life
- Daylight readable LCD display with Red/White multi-color LED back-light.
- Audible and visual notifications for alarms
- Input for analog Fuel Level sender with programmable calibration.

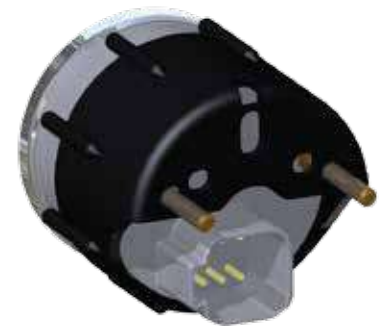

J1939 Stand-Alone CAN Bus display



Instrument Shown
Actual Size



Configurable Two Line Display

Features and Benefits

- SAE J1939 CAN protocol support
- Compact packaging
- 32 X 128 dot matrix graphic LCD
- Displays active and stored faults (SAE J1939 DM1 & DM2)
- Single or Dual Line Display
- Three discrete LED indicators
- Alarm output capable of switching up to 150 mA
- Built in audible alarm (mutable)
- Built-in, sealed, tactile rubber keypad
- Bright, adjustable LED illumination
- Environmentally sealed connectors

NexSysLink®

CAN Instruments Product Family

The NexSysLink CAN Bus display instrument reads and processes SAE J1939 compliant CAN messages.

The sunlight visible, transfective LCD displays operating parameters and is complemented by three discrete alert LED's.

An intuitive menu driven user interface accessed by three built-in tactile switches allows for easy display configuration.

Stand-alone and Master Node (MNI) configurations available. MNI configuration drives NexSysLink® SNI & ASNI gauges.

SAE J1939 Parameter Set*

Parameter Name	SPN	Parameter Name	SPN
Accelerator Pedal Position	91	Engine Fuel Temperature	174
Alternator Voltage	167	Engine Hours	247
Battery Current	114	Engine Oil Level	98
Battery Voltage	168	Engine Oil Pressure	100
Boost Pressure	102	Engine Oil Temperature	175
Coolant Level	111	Hydraulic Oil Level	2602
Coolant Pressure	109	Hydraulic Temperature	1638
Coolant Temperature	110	Intercooler Temperature	52
DEF Level	1761	Percent Load	92
DEF Temperature	3031	Vehicle Miles	245/917
Engine Speed (RPM)	190	PTO Speed	186
Exhaust Gas Temperature	173	Engine Throttle Position	51
Fuel Economy (Average)	185	Vehicle Speed	84
Fuel Level 1	96	Transmission Oil Level	124
Fuel Level 2	38	Transmission Oil Pressure	127
Fuel Delivery Pressure	94	Transmission Oil Temperature	177
Fuel Rate	183		

*Only actively broadcast parameters appear on the LCD.



ATV/RTV manufacturing

Analog MG3000

A complete solution for the small engine market. This compact instrument provides a single source view of the critical engine information without the need for an ECU to send data. The analog inputs are converted into digital information which can be displayed on the LCD and to move the digital stepper motor driven pointer.

A large sun-light readable LCD provides all of the information an operator will need at a quick glance.

Supports RPM, Temperatures, Fuel Level, Gear Position, Battery, Hourmeter, Trip, Odometer, Service Intervals and Alarms.



Features

- Sun-light readable display
- Super-Bright LED warning lights and audible alarms
- Analog / Switched inputs
- Weather resistant connectors
- Environmentally sealed enclosure
- Programmable Service Indicators
- Gear Position
- Speed by PPM and Drive-A-Mile

Digital MG3000 Tachometer/Speedometer



EntelNet™ - WD100 - Wireless CAN Bus Module



Discrete Gauges

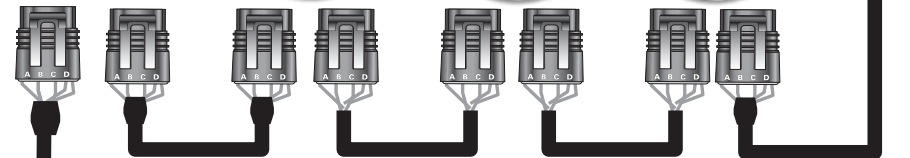
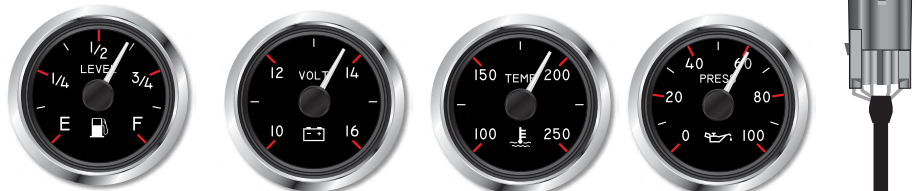

Faria Bus Faria Bus Faria Bus Faria Bus

Information from the ECU

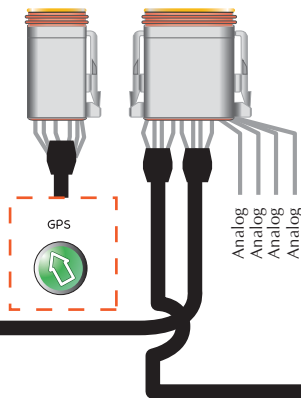

Faria Bus

Analog or Digital (CAN) MG3000 has the information the user wants right at their fingertips.

Fits a typical round 4 3/8" (112mm) panel hole.

Digital Faria Bus

The Faria Bus is a serial communications protocol that connects Faria Beede gauges to one another in a plug-N-play system.

A simple connection from gauge to gauge sends signal and power information down the line. Each gauge receives all the information it needs to display the required information.

Connect multiple devices on one Faria Bus network.

Just plug it in!

With the Faria Bus network you don't have to worry about how it will connect. The Wireless module simply connects to the Faria Bus cable. Mount the module and you are done.

GPS Speedometers



Display (Optional)

Choose between one of two functions for the optional LCD display. Course Over Ground or Odometer and Hourmeter.

Course Over Ground

The LCD display shows Heading and Compass and is back-lit for readability in inclement weather.

The LCD displays Compass Rose headings and actual course over ground heading. Heading is updated in 1° increments.

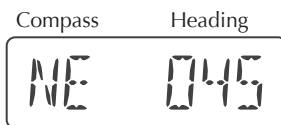

Odometer/Hourmeter

The display is a seven character LCD and can display up to 9,999,999 units in increments of .1 units. The LCD is back-lit with diffused LED light to provide maximum readability.

Displays Odometer or "Engine Running Only" Hourmeter hours.



Accuracy

The GPS Speedometer has a Speed accuracy of +/- 1 MPH while moving and a hot (normal stand-by) start up time (TTF - time to first fix) of about 1 second or a TTF from a cold (no power applied) start of up to 30 seconds.

Heading accuracy is +/- 1 Degree.

Interface

The dial face is illuminated with a premium LED lighting system.

Graphics

Faria Beede Instruments can help design your own custom graphics. Many dial ranges and scales are available including lens type, bezel color, pointer color and back-lighting.

Available in multiple Speed ranges to 80 MPH, 130 KPH, 50 and 70 KNOTS

available in
MPH • kPH • KNOTS

Enclosure

The enclosure is molded from Polycarbonate plastic with integrated Deutsch style connector shells (sockets) or studded case and is sealed against water intrusion in accordance with Ingress Protection (IP) rating IP67. Wires terminate to a sealed Deutsch weatherproof connector or ring terminals. This wire configuration allows the GPS Speedometer to work as a **Plug and Play** addition to your current dash.

Sizes for a standard 4 inch (85 mm) 5 (112 mm) and 2 inch (53 mm) instrument dash hole.

A Speedometer To Fit Your Needs

The GPS Speedometer is available in a wide varieties of capabilities and functions. Because every need is different.

Deutsch connectorized harness

This premium style Speedometer is designed with the very latest technology. It is designed to fit directly into today's dash harnesses with easy Plug and Play connectors. Premium LED lighting and an optional diffused LCD display.

Available in 5-inch, 4-inch and 2-inch styles.

Studded harness

The Studded Speedometer offers an easy way to add GPS technologies to your dash. Designed to fit into existing dash harnesses all ready installed. The Studded Speedometer connects directly to the battery and ground without the addition of a costly connector. Edge lit dials are easy to read in foul weather. Available in all Faria Classic styles.

Available in 4-inch and 5-inch styles.

Stand-alone GPS Antenna

The new antenna is small in size but packs a lot inside. The GPS antenna uses a highly accurate 48 channel GPS receiver.

Designed to connect directly into the NMEA0183 harness. Use the new GPS antenna wherever you would use the current GPS antennas.

Ultra fast Satellite acquisition times (TTF), with Speed Accuracy of +/- 1 MPH. Works better than the traditional GPS antennas at just a fraction of the size.



Shown actual size

Snap-In Multifunction Gauges

Designed to SAE specifications for Dust, Vibration and Water intrusion. The Snap-In instruments provide a Heavy Duty instrument in a easy to install push-in case manufactured in the USA.

This multifunction instrument provides many useful features in a small compact design. Available functions include; Inductive Tachometer, Hourmeter, Programmed Service Intervals and an analog discrete function (Ammeter, Voltmeter, Water Temp, Oil Temp, Oil Pressure, Fuel Level, Fuel Pressure)

No back clamp, washers, nuts or tools are required to install the gauge into your panel.



Features and Benefits

- Inductive Tachometer with Hourmeter
- Programmable Service Intervals with alarm
- US standard and metric values
- Poly carbonate cases for corrosion resistance and long life
- No hassle mounting - reduces installation time
- Available with or without embedded Digital Hourmeter
- 2 inch gauges - Ammeter, Voltmeter, Water Temp, Oil Temp, Oil Pressure, Fuel Level, Fuel Pressure and Hourmeter



J-1939 CAN Bus Panels, Clusters and Instruments



New designs, including the popular MG3000 digital LCD display, adds the features of our best selling digital instrument in a single panel cluster design. Customize your panel with warning lights and discrete gauge functions.

SAE J1939

J-1939 Hourmeter with Snap-In case

SAE J1939

Designed to SAE specifications. The Faria Beede Snap-In instruments provide a Heavy Duty instrument in a easy to install push-in case manufactured in the USA.

No back clamp, washers, nuts or tools are required to install the gauge into your panel.

Features and Benefits

- Custom icon configurations available
- SAE J-1939 CAN protocol support
- Nylon cases for corrosion resistance and long life
- No hassle mounting - reduces installation time



Shown actual size

Digital Hourmeter with Snap-In case

The Digital Hourmeter starts recording Engine Running Only hours when the voltage is measured above 12.8 VDC. The Faria Beede Snap-In instruments provide a Heavy Duty instrument in a easy to install push-in case manufactured in the USA.

No back clamp, washers, nuts or tools are required to install the gauge into your panel.

Features and Benefits

- Engine Running Only Hourmeter
- Nylon cases for corrosion resistance and long life
- No hassle mounting - reduces installation time



Shown actual size

Patented Snap-In case



With its patented mounting design the Snap-In instrument case is designed to install easily and reduce costs. Simply push through the mounting hole. The case springs out to hold your gauge in place.

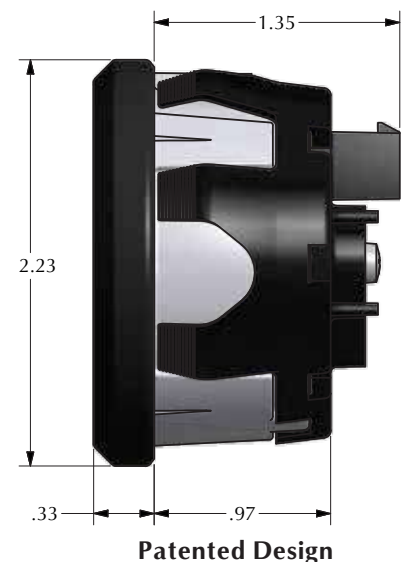



WD100



Connected directly to the CAN Bus, Real-Time data is sent by the EntelNet™ wireless module via Wi-Fi™.

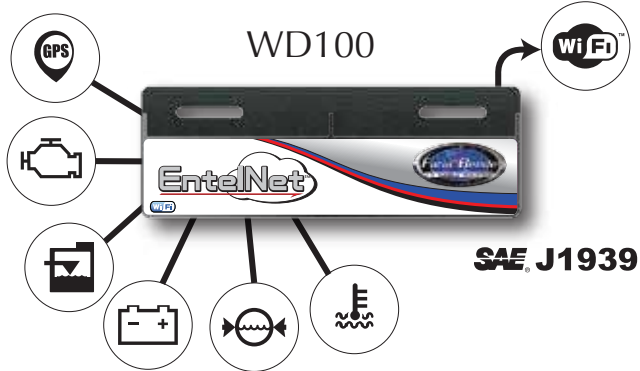

The data (GPS speed, Map position, Instrument data and CAN error codes) is displayed in an easy to read website by web browser or can be displayed on an Android™ device i.e. Smart Phone, Tablet using the Faria Beede app.

The engine information can then be sent to a repair facility, via e-mail, giving your repair technician a heads up that you're having problems.

Standard Features

- No additional costs
- Send the engine and other critical data anywhere in the world to be diagnosed.
- Helps reduce warranty costs and can help lessen repair time.
- Data can be viewed on a secure website for remote systems diagnostics.

Remote Dashboard App



Made for Android™



Coming Soon!



Faria Beede app built for Android™

- Standard and Secondary instruments
- Tank monitoring and control
- Fuel Management
- Error Codes

Step 1
(Connect to EntelNet™[web browser])

Step 2
(Send e-mail)

Step 3
(Response)



Commercial and Industrial Products

Faria Beede offers a wide range of Analog instruments with Digital functions

Available in a wide variety of styles and configurations.



Digital Stepper Motor instruments



- Direct Replacement for Analog Gauges
- Stepper Motor Driven gauges for increased Accuracy and Gauge Life.
- Uses Analog inputs
- Can be configured for any Analog configuration.

J-1939 Tell-Tale Indicator with 30 Icon Positions



- Environmentally sealed connectors
- Custom icon configurations available
- Up to ten discrete inputs switched either high or low
- SAE J-1939 CAN protocol support
- Connects seamlessly with NexSysLink MNI instruments
- Bright LED illuminated tell-tales
- Built in audible alarm and switched output

NexSysLink®

CAN Instruments Product Family

This CAN based product complements the NexSysLink® instrument system by providing thirty LED illuminated operator alert tell-tales along with an audible alarm to alert users to multiple fault conditions.

Product Description

The alert panel directly reads and processes SAE J-1939 compliant CAN messages, serial data from any NexSysLink Master Node Instrument and up to ten factory configurable discrete inputs switched either high or low to activate the tell-tales and/or audible alarm.

A discrete output capable of switching up to one amp and an audible output increase the utility of this product.

Control Instruments for Electronically Governed Engines



The M150L00 Series Control instruments are designed to provide Plug N' Play solutions for installations with existing panel designs. These kits are designed to control J1939 electronically governed engines.

With a full featured J1939 interface the L00 series kits provide a complete interface for virtually any SAE J1939 data. With standard features such as "TSC1 Throttle Control", "Fuel Level Input", "Engine Oil Pressure" and "Engine Shutdown", the L00 series kits provide the most features in the price range.

With the traditional look of a round gauge using the latest microprocessor technology the M150L series products provide the user with a traditional "look and feel" for controlling the latest electronic engines. Incorporating the latest technology allows the M150L products to be fully scalable from a single gauge solution to a full feature multi-gauge applications.

Programmable Tachometer



Programmable Speedometer



- Easy programming (for 1 or 2 axle ranges)
- Hourmeter function available
- Program service intervals
- Store highest speed
- Custom proprietary features available
- Easy calibration -
 - drive a measured mile
 - calibrate from inside cab
 - preset at factory
- Speedometer sensors available

This tachometer can be programmed to function with 1, 2, 4, 6 and 8 cylinder gasoline engines and with most diesel engines, and can be used with most ignition coils including Alternator and Mag pickup inputs.

It is available in a wide range of scales or you can customize to fit your needs.

A versatile design from a leader in the engine monitoring industry, Faria products are designed to give you years of service and worry free performance.



A Tachometer to fit every need Universal Gas and Diesel

Available in 4 and 5 inch sizes with multiple ranges for gasoline and diesel systems;

These tachometers are available for all ignition systems, alternators and diesel engines. Available with or without a digital hourmeter which records up to 999999.9 hours.

2 inch tachometer

Available in ranges from 1500 RPM to 4000 RPM. This 2-inch Tachometer connects to the Alternator signal or Magnetic Pick-up (dip switch settable). The tachometer has four range selections for rough calibration and an adjustment potentiometer for fine adjustment.

Senders, Sensors and Switches

Pressure Switches



Temperature Senders



Adjustable Fuel Level Senders



Pressure Senders



Temp. Sender/Switch



(For Tanks 6 to 25" deep)

(Pre-made panels available)



Serving Industry Leading Companies for more than 100 years.

Kubota

AM General

DOOSAN

**HONDA
MARINE**



KOHLER

SeaDwyer

Husqvarna

SUZUKI



POLARIS

Onan

**MOTOR
HARLEY-DAVIDSON
CYCLES**

EVINRUDE
E-TEC

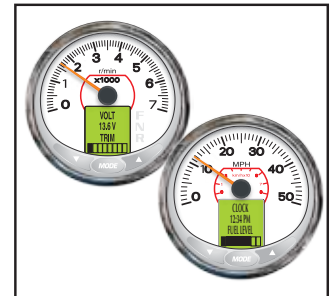

TOHATSU
Outboards

Bank Boy



LOFA
INDUSTRIES



Made in the USA

Faria Beede Instruments, Inc.
P. O. Box 983
Uncasville, CT 06382
860.848.9271
Fax: 860.848.2704
Toll-free: 800.451.8255

fm-002-0033 B 9/2016

Manufactured by the Faria Beede Instruments, Inc., Uncasville CT, USA • Copyright and all other rights reserved.
Our products are continually being improved. Specifications may change without notice.