

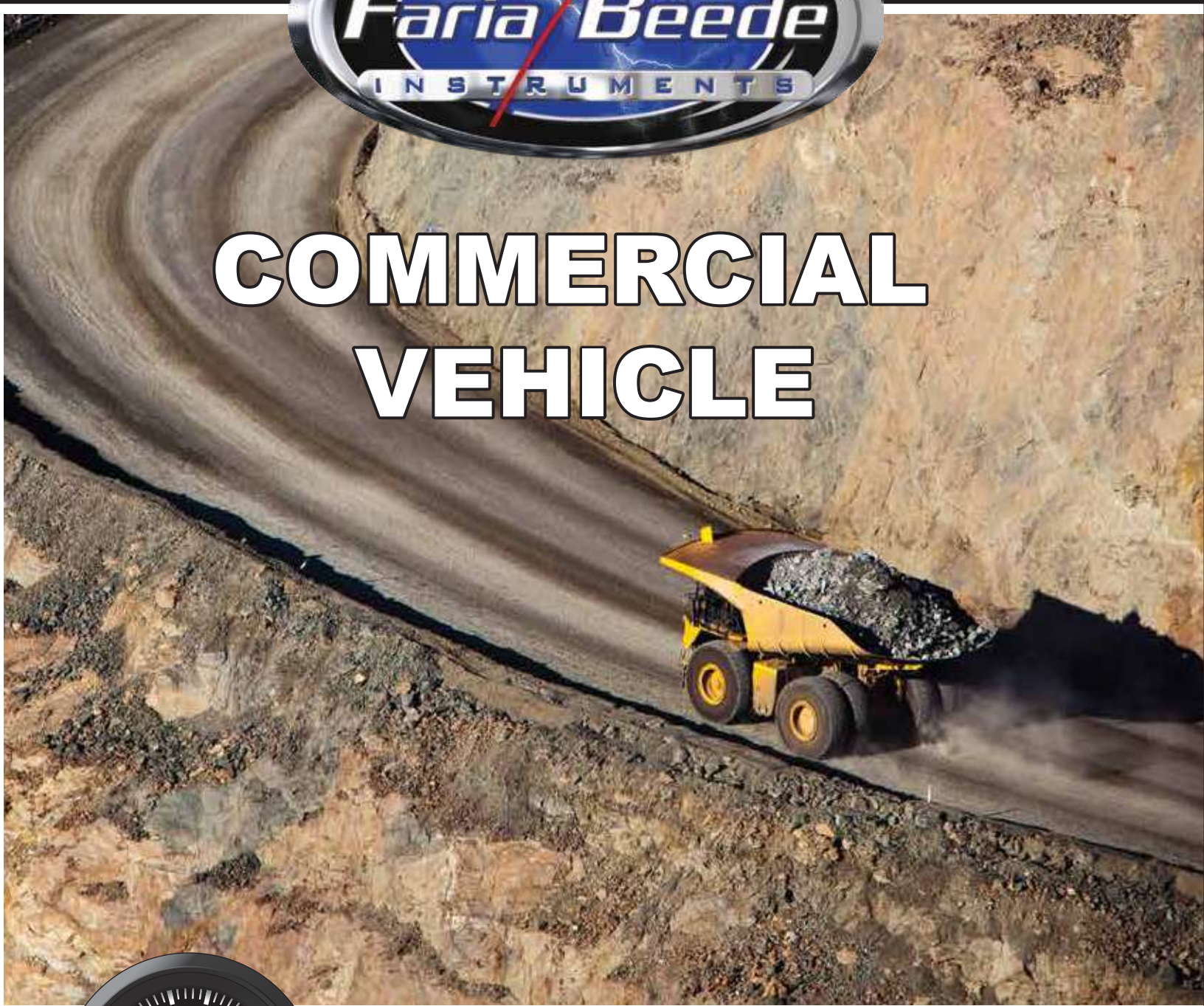

COMMERCIAL VEHICLE





ENGINEERED *Excellence*™
An ISO 9001:2008 Registered Company



Rugged • Reliable • Innovative

Faria Beede Instruments, Inc. has been manufacturing gauges and instruments in Uncasville, CT for more than 60 years. The company offers a full complement of analog and digital engine monitoring and telematic solutions for a wide range of global marine, military, industrial and performance industries.

One of the few remaining vertically integrated U.S. manufacturers of SAE J1939 instrumentation, Faria Beede provides some of the best turnaround times and responsive support in the industry. This is only possible by having total control of all aspects of design, engineering and manufacturing.

Whether your needs are for the simplest or the more advanced computerized engines, Faria Beede has the instrumentation solution that is right for you.

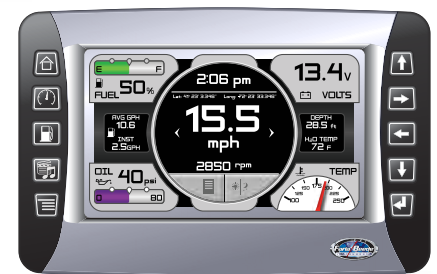

Instruments for

Automotive
Commercial
Industrial
Performance
Recreational
Marine
Military

www.FariaBeede.com



2" - Stand-Alone J1939 Hourmeter

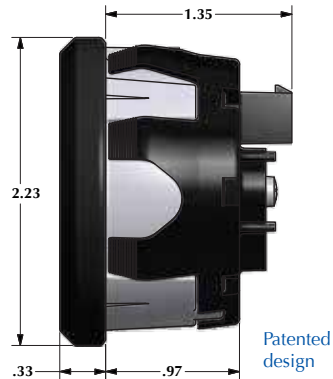

Fits a typical round 2.005" (51mm) panel hole.

The Faria Beede Snap-In J1939 Hourmeter reads the hours directly from the CAN bus and the engine ECU. Hours are read in tenths of hours.

Designed to SAE specifications. This instrument provides an easy to install push-in case manufactured in the USA.

No back clamp, washers, nuts or tools are required to install the gauge into your panel.

- Custom icon configurations available
- SAE J-1939 CAN protocol support
- Poly Carbonate cases for corrosion resistance and long life
- Patented, No hassle mounting - reduces installation time

2" - Stand-Alone CAN Bus Display



Configurable Two Line Display

Fits a typical round 2 1/16" (53mm) panel hole.

NexSysLink[®] CAN Instruments Product Family

The NexSysLink CAN Bus display instrument reads and processes SAE J1939 compliant CAN messages.

The sunlight visible, transfective LCD displays operating parameters and is complemented by three discrete alert LED's.

An intuitive menu driven user interface accessed by three built-in tactile switches allows for easy display configuration.

Stand-alone and Master Node (MNI) configurations available. MNI configuration drives NexSysLink[®] SNI & ASNI gauges.

- SAE J1939 CAN protocol support
- Compact packaging
- 32 X 128 dot matrix graphic LCD
- Displays active and stored faults (SAE J1939 DM1 & DM2)
- Single or Dual Line Display
- Three discrete LED indicators
- Alarm output capable of switching up to 150 mA
- Built in audible alarm (mutable)
- Built-in, sealed, tactile rubber keypad
- Bright, adjustable LED illumination
- Environmentally sealed connectors

2" - J1939 CAN Display



Available Display Functions

Voltage	Trip Data (Re-settable)
Engine Boost	Engine Hours
Engine Load	Fuel Used
Engine Coolant Temp.	
Fuel Level, Tank 1	Odometer
DEF Level	Fuel Rate
Oil Pressure	
Speed Over Ground	All screens can be
Engine Speed	customized for OEM
Transmission Pressure	volume orders.
Transmission Temp.	
Fuel Instantaneous	

Fits a typical round 2 1/16" (53mm) panel hole.

The CAN display instrument is designed to read and process SAE J1939 compliant CAN messages. The large sunlight readable, transfective LCD displays operating parameters with easy to read characters. The "second line" data displays a continual readout of the engine's hours or "over the road" Odometer.

Up to 12 display pages can display the information being sent by the engine ECU, including Trip data and advanced Fuel Management. Should a DM1 or J1939 alarm occur the J1939 CAN display will activate a 13th display screen for the operator to log the alarm, while maintaining the regular data screens.

An audible beep will sound when a CAN error message is initiated from the ECU and the LCD will flash warning the operator of a fault or alarm. This alarm may be silenced temporarily by the user.

A full list of faults is stored locally on the device.

J1939 FAULT
SPN XXXXX
FMI XX
CT XX

On board programmable parameters allow for customizing of menu options including, Max Speed, Audio, Fuel Tank, Units and Master Program Reset (Return to factory settings).

- SAE J-1939 CAN protocol support
- Poly Carbonate cases for corrosion resistance and long life
- Daylight readable LCD display with Red/White multi-color LED back-light.
- Audible and visual notifications for alarms
- Input for analog Fuel Level sender with programmable calibration.

2" - J1939 CAN Tell-tale Indicator



Fits a typical round 2 1/16" (53mm) panel hole.

SAE J1939 CAN and NMEA2000 tell-tale product provides 4 LED illuminated operator alert tell-tales and one programmable switched output.

The large, front facing operator button provides manual access to the switched output. Giving the operator control over a connected CAN controlled device. Additionally the switched output can be automatically triggered by any CAN message (DM1 or other) detected by the Indicator.

The alert panel directly reads and processes compliant CAN messages. Multiple configurations are available based on your needs.

- Environmentally sealed connectors
- Custom icon configurations available
- SAE J-1939 and NMEA2000 CAN protocol support
- Bright LED illuminated tell-tales
- Factory programed switched output can be triggered by any of the Tell-Tales or operated by manual control.

Snap-In Multifunction Gauges



Just push

With its patented mounting design the Snap-In J-1939 Hourmeter is designed to install easily and reduce costs.

Simply push through the mounting hole. The case springs out to hold your gauge securely in place.

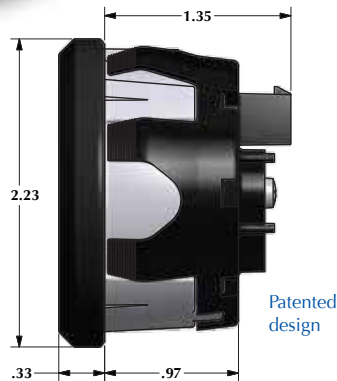

Designed to SAE specifications for Dust, Vibration and Water intrusion. The Snap-In instruments provide a Heavy Duty instrument in a easy to install push-in case manufactured in the USA.

This multifunction instrument provides many useful features in a small compact design. Available functions include; Inductive Tachometer, Hourmeter, Programmed Service Intervals and an analog discrete function (Ammeter, Voltmeter, Water Temp, Oil Temp, Oil Pressure, Fuel Level, Fuel Pressure)

No back clamp, washers, nuts or tools are required to install the gauge into your panel.

With its patented mounting design the Snap-In gauge is designed to install easily and reduce costs. Simply push through the mounting hole. The case springs out to hold your gauge in place.

- Inductive Tachometer with Hourmeter
- Programmable Service Intervals with alarm
- US standard and metric values
- Poly carbonate cases for corrosion resistance and long life
- No hassle mounting - reduces installation time
- Available with or without embedded Digital Hourmeter
- 2 inch gauges - Ammeter, Voltmeter, Water Temp, Oil Temp, Oil Pressure, Fuel Level, Fuel Pressure and Hourmeter
- * Connectorized Molex connectors

Fits a typical round 2.005" (51mm) panel hole.

2" - Magnetic Pick-up Tachometer



Fits a typical round 2 1/16" (53mm) panel hole.

This 2-inch Tachometer connects to the Magnetic Pick-up sensor. The tachometer has four range selections for rough calibration and an adjustment potentiometer for fine adjustment.

The use of DIP switches on the back of this tachometer allows a rough calibration selection for the desired teeth.

Analog MG3000

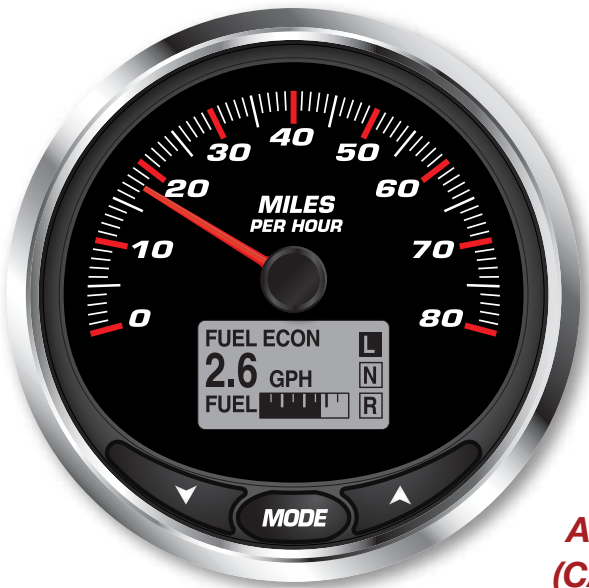

Analog or Digital (CANBus) MG3000 has the information the user wants right at their fingertips.

Fits a typical round 4.375" (112mm) panel hole.

A complete solution for the small engine market. This compact instrument provides a single source view of the critical engine information without the need for an ECU to send data. The analog inputs are converted into digital information which can be displayed on the LCD and to move the digital stepper motor driven pointer.

A large sun-light readable LCD provides all of the information an operator will need at a quick glance.

Supports RPM, Temperatures, Fuel Level, Gear Position, Battery, Hourmeter, Trip, Odometer, Service Intervals and Alarms.

- Sun-light readable display
- Super-Bright LED warning lights and audible alarms
- Analog / Switched inputs
- Weather resistant connectors
- Environmentally sealed enclosure
- Programmable Service Indicators
- Gear Position
- Speed by PPM and Drive-A-Mile

Digital Faria Bus



Digital MG3000 Tachometer/Speedometer

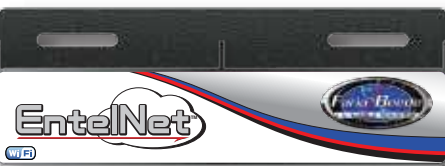

Discrete Gauges

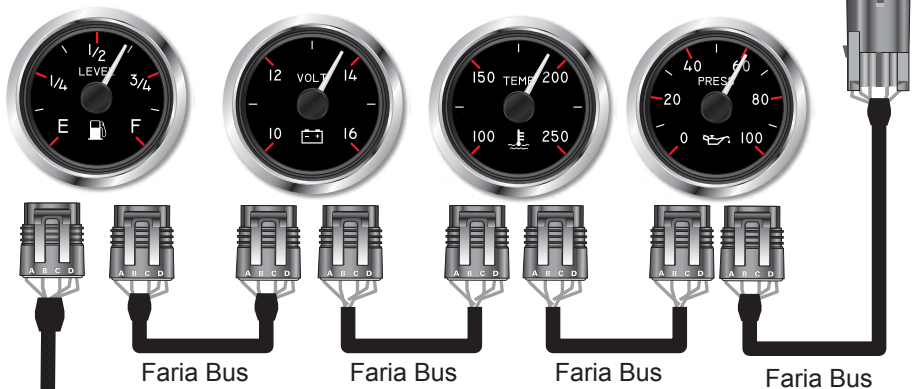

Information from the ECU

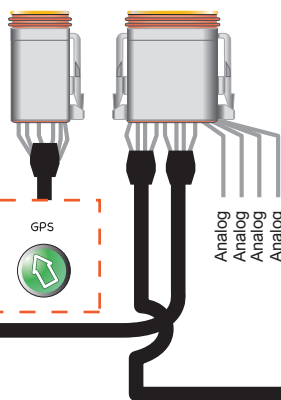

Faria Bus

The Faria Bus is a serial communications protocol that connects Faria gauges to one another in a plug-N-play system.

A simple connection from gauge to gauge sends signal and power information down the line. Each gauge receives all the information it needs to display the required information.

Connect multiple devices on one Faria Bus network.

Just plug it in!

With the Faria Bus network you don't have to worry about how it will connect. The WD100 - Wi-Fi module simply connects to the Faria Bus cable. Mount the module and you are done.

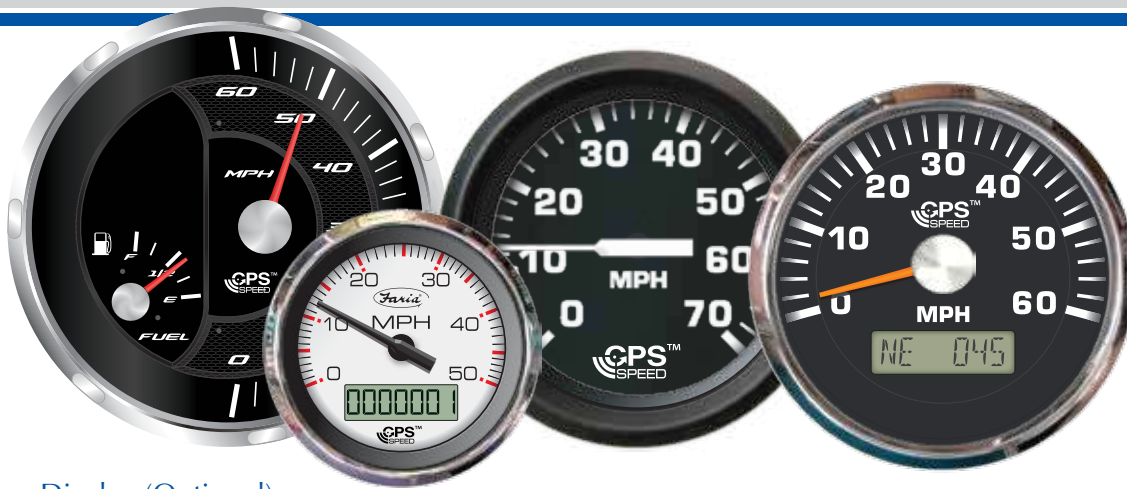

Antenna built in.
No additional parts needed.

Display (Optional)

Choose between one of two functions for the optional LCD display. Course Over Ground or Odometer and Hourmeter.

Course Over Ground

The LCD display shows Heading and Compass and is back-lit for readability in inclement weather.

The LCD displays Compass Rose headings and actual course over ground heading. Heading is updated in 1° increments.

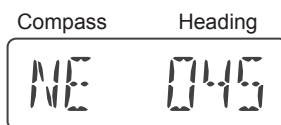

Odometer/Hourmeter (OEM volume purchases only)

The display is a seven character LCD and can display up to 9,999,999 units in increments of .1 units. The LCD is back-lit with diffused LED light to provide maximum readability.

Displays Odometer or "Engine Running Only" Hourmeter hours.



Accuracy

The GPS Speedometer has a Speed accuracy of +/- 1 MPH while moving and a hot (normal stand-by) start up time (TTFF - time to first fix) of about 1 second or a TTFF from a cold (no power applied) start of up to 30 seconds.

Heading accuracy is +/- 1 Degree.

Interface

The dial face is illuminated with a premium LED lighting system.

Graphics

Faria Beede Instruments can help design your own custom graphics. Many dial ranges and scales are available including lens type, bezel color, pointer color and back-lighting.

Available in multiple Speed ranges to 80 MPH, 130 KPH, 50 and 70 KNOTS

available in
MPH • kPH • KNOTS

Enclosure

The enclosure is molded from Polycarbonate plastic with integrated Deutsch style connector shells (sockets) or studded case and is sealed against water intrusion in accordance with Ingress Protection (IP) rating IP67. Wires terminate to a sealed Deutsch weatherproof connector or ring terminals. This wire configuration allows the GPS Speedometer to work as a Plug and Play addition to your current dash.

Sizes for a standard 4 inch (85 mm) 5 (112 mm) and 2 inch (53 mm) instrument dash hole.

A Speedometer to fit your needs

The GPS Speedometer is available in a wide varieties of capabilities and functions. Because every need is different.

Deutsch connectorized harness

This premium style Speedometer is designed with the very latest technology. It is designed to fit directly into today's dash harnesses with easy Plug and Play connectors. Premium LED lighting and an optional diffused LCD display.

Available in 5-inch, 4-inch and 2-inch styles.

Studded harness

The Studded Speedometer offers an easy way to add GPS technologies to your dash. Designed to fit into existing dash harnesses all ready installed. The Studded Speedometer connects directly to the battery and ground without the addition of a costly connector. Edge lit dials are easy to read in foul weather. Available in all Faria Classic styles.

Available in 4-inch and 5-inch styles.

Stand-Alone GPS Antenna

The new antenna is small in size but packs a lot inside. The GPS antenna uses a highly accurate 48 channel GPS receiver.

Designed to connect directly into the NMEA0183 harness. Use the new GPS antenna wherever you would use the current GPS antennas.

Ultra fast Satellite acquisition times (TTFF), with Speed Accuracy of +/- 1 MPH. Works better than the traditional GPS antennas at just a fraction of the size.



Shown actual size

MG1000



Specifically designed to work with the leading engine manufacturers. Dial scales and styles can be customized for OEM volume orders.

The MG1000 displays the critical data and information that operator demands in a simple, lower-cost, intuitive package.

Multiple Discrete Gauges Available

Multiple discrete gauges are available in multiple configurations including Multifunction instruments and individual gauges. Each gauge is daisy chained into the system simplifying installation. Add up to 10 gauges from a single gateway systems instrument.

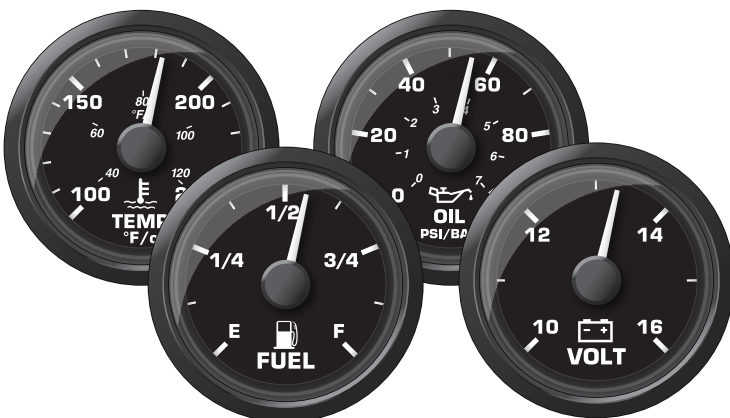

Fits a typical round 3 3/8" (85mm) or 4 3/8" (112mm) panel hole.

The MG1000 is the stepping stone of digital instrumentation. This innovative digital gauge system requires no LCD's, no system initialization, no menu setups and no user manual interaction for use - ever! Just install and go!

The MG1000 gauge system displays engine ECU data and alarms. Installation is simplified by reducing wiring and setup time. Our instruments communicate with the engine ECU for the most accurate information.

This system is the lowest cost, most user-friendly digital product in the market for customers installing digital technology. Multiple analog inputs and warning lights reduce cost while still providing the customer with everything they need.

Upgrade to the MG3000 system for an even wider variety of options and features. The Faria product suite offers a multitude of accessory gauges available to connect to the MG1000 system including a 2" fuel flow gauge to show fuel economy. The combinations are limitless!!

- Can be directly connected to J1939 CAN Bus systems
- "Daisy Chain" connections, add additional features, connect the MG3000 with the same harness
- NMEA0183 input for GPS Speed
- A single Tachometer can monitor up to 4 analog signals
- Utilizes both analog and digital inputs to reduce system cost
- Stepper motor gauges (for greater accuracy and durability)
- Deutsch and Packard water tight connectors
- LED lighting is standard
- Custom cosmetic options upon request
- Multiple 5"/4"/2" discrete instruments are available



MG3000 - Mini Gateway



A user friendly digital engine monitoring solution.

Customize to fit your needs.
Available in 4 and 5 inch.
With or with out buttons.



SAE J1939
SAE J1708



Display

The 128x64 color LCD display, available on the MG3000, provides an easy to read viewing area for system configuration and virtually any data reported by the ECU. The new daylight readable LCD is visible even in direct sunlight.

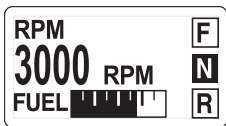

The display is available with multiple RGB colors.



Interface

The MG3000 can be configured with or with out the three front-mounted push button function selectors. These buttons control the user configurable software and provide access to variable menus and selections.

The MG3000 also allows for remote input device for control of the screens and data viewing.

Graphics

Faria Beede can help design your own custom graphics. Many dial ranges and scales are available including lens type, bezel color, pointer color and back-lighting.

The digital "MG" or mini-gateway system, available in the Speedometer or Tachometer, is a feature-rich, intuitive engine monitoring solution for the instrument market.

The digital instrumentation communicates directly with the J1939, NMEA2000 and SmartCraft protocols used by the engine ECU providing an important link between the operator and the engine ECU. With just a push of a button the operator can tell the status of the health of the engine including diagnostic messages, fault alerts, and parameter information.

With a full featured J1939 interface the MG3000 series instruments provide a complete interface for virtually any SAE J1939 data.

Connect to analog and digital signals to reduce installed costs significantly.

The MG3000 and other digital instruments from Faria Beede are fully scalable from a single gauge solution to a full feature multi-gauge applications.

- Tier 4 Compatible
- LCD data are available in 5 languages.
- Seasonal and Trip Data.
- Pop-Up screens for quick information display and warnings.
- Alarm codes with suggested actions.
- Data log for fault codes.
- Monitor up to 5 tanks or other analog signals.
- Calibrate Fuel Level and Speed in gauge.
- Superior Sunlight readable display.
- Units can be displayed in US standard or Metric
- Gear position indicators

Inputs

- CAN Bus (J1939, NMEA2000 and SmartCraft)
- Direct Pressure
(30 PSI -200 kP) and (145 PSI - 10000kP)
- Analog Inputs
5 Analog inputs are available (Customer specific)

Enclosure

The enclosure is molded from Polycarbonate plastic with integrated Deutsch style connector shells (sockets) and is sealed against water intrusion in accordance with Ingress Protection (IP) rating IP67. Wires terminate to a sealed Deutsch weatherproof connector.

The case is available in three water tight configurations from fully waterproof to vented.

Depending on instrument type the case is available in 2, 4 and 5 inch standard hole sizes.

Accuracy

A digital stepper motor drives the pointers in the digital instruments. The stepper motor increases the accuracy and reliability of the instrument while reducing jittery pointers and providing longer life with a lower power requirement.

Connectors

A water tight 12-pin and 6-pin connector is used for plug-in installation.

Maintenance Interval

User configurable maintenance interval. When programmed system provides warning message when maintenance interval has expired.

Master Node Instrument (MNI)



Product Type and Range

Tachometer	Speedometer
0-4000 RPM	0- 30 MPH
0-6000 RPM	0- 50 MPH
0-8000 RPM	0- 85 MPH
	0-145 MPH

Custom ranges available

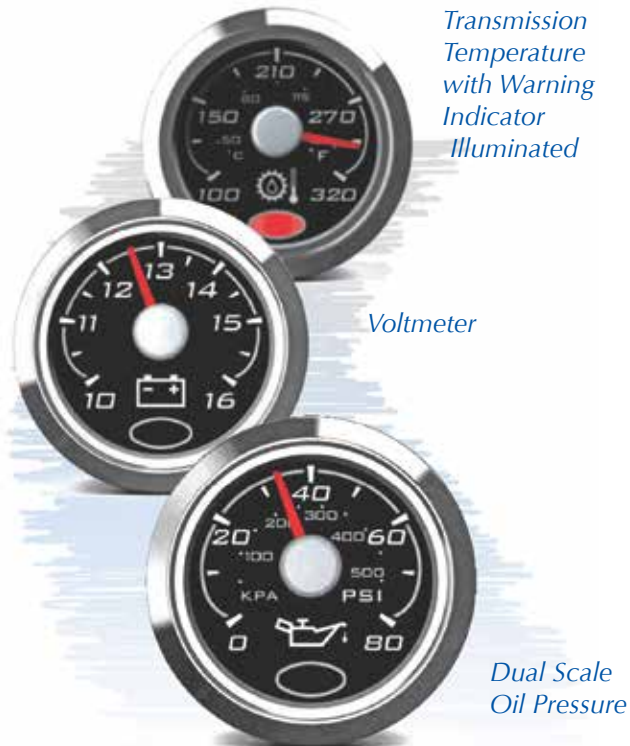

*Transmission
Temperature
with Warning
Indicator
Illuminated*

Voltmeter

*Dual Scale
Oil Pressure*

NexSysLink®, as its name implies, is the next generation instrumentation system from Faria Beede that connects you with critical operating data transmitted by CAN (Controller Area Network) based apparatus. Suitable for a wide range of industries and applications, these instruments combine the best of analog and digital display technologies that provide the ability to quickly and accurately read industry standard CAN protocols.

Thoughtful, expert design fills NexSysLink® instruments with practical and functional features users expect and appreciate. An intuitive menu driven user interface allows you to quickly configure and use the instruments according to your needs. Three discrete inputs give users the freedom to choose the style and location of interface menu switches (Mode/Enter, Up, Down) to improve the ergonomics of panel designs such as eliminating the awkwardness of reaching through a steering wheel. Configurable alert notification settings are easily tailored to prevent costly breakdowns or repairs of your equipment. Simple system wiring features a rugged, sealed and widely used connector to significantly reduce installation time and costs.

- SAE J1939 CAN protocol support
- Large transfective dot matrix LCD
- Advanced stepper motor technology
- Supports up to three discrete analog sender
- Displays faults and warnings inputs including NMEA 0183 (GPS/Smart Transducer)
- Drives up to sixteen Slave Node Instruments (SNI)
- Factory custom configurations and setups Analog Slave Node Instruments (ASNI)
- Bright LED illumination
- Bold, easy to read graphics
- Domed or flat glass lenses
- Environmentally sealed connectors

Customizable Features

Bezel profile, material and finish

Dial face graphics and colors

Company logo

Pointer cap and blade color

Trim ring color

Illumination color

2-inch Slave Node Instrument (SNI)

The SNI receives and displays data transmitted by a Master Node Instrument (MNI)

The instrument provides a full 250° pointer sweep and a large engine fault and warning indicator.

Multiple gauge styles and ranges available, including; Air PSI, DEF level, Temperature, Voltmeter and Ammeter. Gauges available in single scale and dual scale instruments.

Your Application. Your Choice.

NexSysLink® family of instruments give you the option of choosing between a fully integrated daisy chain approach or a group of discretely wired stand-alone instruments. Adding additional instruments, regardless of the approach, always remains an option.

Fully Integrated

This configuration consists of a Master Node Instrument (MNI) that will read and process CAN data from the apparatus' ECU or discrete analog sender(s). The MNI will display and transmit the processed data to complementary minor or slave node instruments to provide an analog readout of the desired operating data. The instruments are connected via a simple three-wire daisy-chain style harness. This approach significantly reduces dash or control panel wiring yet still offers the ability to easily expand the number of minor gauge nodes to a maximum of sixteen.



Master Node Instruments (MNI)

Reads and processes CAN and/or analog sender data then transmits to all slave node instruments using a three-wire daisy-chain harness.

- Available in 3 or 5" sizes.
- LCD displays operating parameters
- Lockable menu options
- Up to three analog input channels

Slave Node Instruments (SNI)

Receives and displays data transmitted by MNI.

- Available in 2, 3 or 5" sizes.
- Multi-gauge configurations available
- Engine fault and warning indicator standard on all SNI's

Fault-Warning-Alarm (SNI)

Receives and displays data transmitted by an MNI

Provides users with additional fault and warning.

- Available in 2 or 3" sizes.
- Relay outputs
- Audible alarm output with mute option.

2" Analog SNI (ASNI)

Receives data directly from analog senders and transmits information back to the MNI for display on the LCD.

A perfect way to expand analog inputs beyond the those found in the MNI.

- Supports resistive or voltage type senders.
- User settable alarms through MNI interface
- Illumination intensity set and controlled through MNI.

Stand-Alone

When your application requires each individual instrument to read and process CAN data directly from an ECU or analog sender, NexSysLink® instruments will satisfy that need as well. With this approach, each instrument connects directly to a CAN signal or sender and processes the information independently. Stand-alone instruments can enhance a fully integrated approach by allowing you to mount the instrument remotely from the main dash instruments without having to connect back to the main dash. This reduces wiring costs yet places ECU or sender information exactly where you need it.

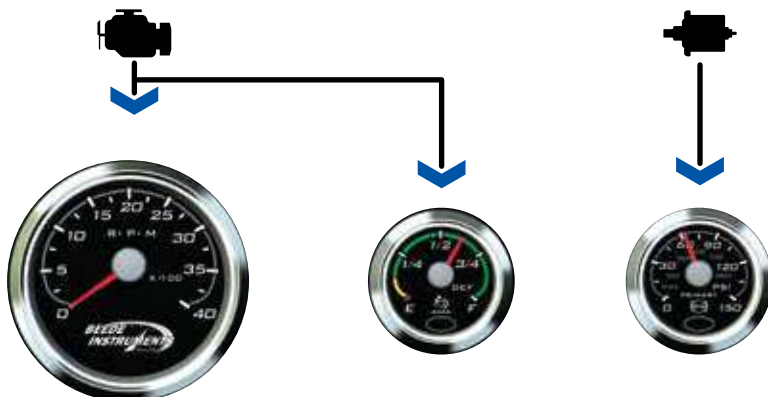

2" Stand-Alone Node Instruments

Connects directly to a CAN data bus or analog sender. The choice when only a few parameters need monitoring or to complement an existing factory installed digital display.

- Various instruments included but not limited to:
 - DEF
 - Coolant Temperature
 - Oil Pressure
 - Oil Temperature
- Two factory set warning fault indicators
 - Amber (flashing)
 - Red (steady)

J-1939 Tell-Tale Indicator



This CAN based product complements Faria Beede's J1939 CANBus instrument systems by providing up to thirty LED illuminated operator alert tell-tales along with an audible alarm to alert users to multiple fault conditions.

Product Description

The alert panel directly reads and processes SAE J-1939 compliant CAN messages, serial data from any NexSysLink Master Node Instrument or MG3000™ and up to ten factory configurable discrete inputs switched either high or low to activate the tell-tales and/or audible alarm.

The product meets OBD regulatory requirements for wait-to-start lamp by performing required circuit continuity check.

A discrete output capable of switching up to one amp and an audible output increase the utility of this product.

IP 65 compliant for water ingress and protection.

16 Icon Position Tell-Tale

- Environmentally sealed connectors
- Custom icon configurations available
- Up to six discrete inputs switched either high or low
- SAE J-1939 CAN protocol support
- Connects seamlessly with NexSysLink MNI instruments
- Bright LED illuminated tell-tales
- Built in audible alarm and switched output
- Factory configurable for +12V or +24V systems

30 Icon Position Tell-Tale

- Environmentally sealed connectors
- Custom icon configurations available
- Up to ten discrete inputs switched either high or low
- SAE J-1939 CAN protocol support
- Connects seamlessly with NexSysLink MNI instruments
- Bright LED illuminated tell-tales
- Built in audible alarm and switched output



2" DPF Display - SAE J1939 - Tier 4

Fits a typical round 2 1/16" (53mm) panel hole.

Single Parameter Display

Dual Parameter Configurable

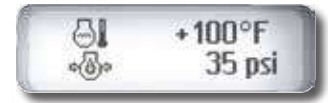

*Tier 4
Compliant
Start-up Screen*



The NexSysLink® CAN Bus display instrument reads and processes SAE J1939 compliant CAN messages then displays the CAN message parameter values on a two-line dot-matrix LCD.

The instrument's small footprint, LCD information display and alert LEDs make it a versatile tool for use in various locations of a vehicle or engine powered equipment such as the engine compartment where users or service technicians require a real-time convenient display of engine operating information.

Applications for the instrument includes fire apparatus pump panels, portable power and compressor units as well as fixed engine applications.

The sunlight visible transfective LCD displays operating parameters and is complemented by three discrete alert LED's.

An intuitive menu driven user interface accessed by three built-in tactile switches allows for easy display configuration.

Stand-alone and Master Node (MNI) configurations available. MNI configuration drives the SNI and ASNI instruments.

Front sealing IP 67 compliant

2-inch DEF Level Instrument - SAE J1939

Fits a typical round 2 1/16" (53mm) panel hole.



*SPN 5245
001 - Steady-on Red
100 - Fast Blink Red*

*SPN 1761
Steady-on Amber @ 12.5%
Flashing Red @ 2.5%*



Alert LED Control

This NexSysLink® stand-alone instrument directly interfaces to an SAE J1939 compliant CAN bus without the need for a Beede Master Node Instrument or some other gateway device to display DEF (Diesel Exhaust Fluid) level.

The instrument employs advanced stepper motor technology that provides a full 250° pointer sweep.

Standard features include LED illumination and an environmentally sealed connector.

A large, bright LED alert indicator activates to provide visual warning when the DEF level is low.

Front sealing IP 67 compliant

- SAE J1939 CAN protocol support
- SPN 5245 or 1761 LED alert styles available
- Stand-alone operation
- Advanced stepper motor technology
- Bright, adjustable LED illumination
- Environmentally sealed connectors

Electronic Programmable Speedometer

Fits a typical round 3 3/8" (85mm) panel hole.



Electronic speedometers operate by capturing pulses produced by a sensor. The pulses are then electronically converted to a speed-reading very much like a tachometer converts ignition pulses to RPM.

Odometer

The speedometer contains an odometer to maintain a record of the total mileage and trip mileage.

This display cannot be reset. A quick press of the an external push-button changes the display to the Trip odometer.

Trip Odometer

The Trip odometer allows operator to keep a record of the trip miles independent of the Odometer.

The Trip Odometer is fully user Re-settable.

- Easy calibration -
 - drive a measured mile,
 - calibrate from inside cab
 - preset at factory

Programmable Tachometer

Fits a typical round 3 3/8" (85 mm) panel hole.



This tachometer can be programmed to function with 1, 2, 4, 6 and 8 cylinder gasoline engines or with diesel engines, and can be used with most ignition coils including Alternator and Mag pickup inputs.

It is available in a wide range of scales or you can customize to fit your needs.

A versatile design from a leader in the engine monitoring industry, Faria Beede products are designed to give you years of service and worry free performance.

Display

The display is a seven character LCD and can display up to 9,999,999 units in increments of .1 units. The LCD is back-lit with diffused LED light to provide maximum readability.

Displays "Engine Running Only" **Hourmeter** hours.



A Tachometer to fit every need



Programmable Tachometer

Programmable Tachometer

This tachometer can be programmed to function with 1, 2, 4, 6 and 8 cylinder gasoline engines and with most diesel engines, and can be used with most ignition coils including Alternator and Mag pickup inputs.

It is available in a wide range of scales or you can customize to fit your needs.



Diesel Tachometer with Hourmeter

Universal Gas and Diesel

These tachometers are available for all ignition systems, alternators and diesel engines. Available with or without a digital hourmeter which records up to 999999.9 hours.



2-Inch Tachometer

2 inch Tachometer

This 2-inch Tachometer connects to the Alternator signal. The tachometer has four range selections for rough calibration and an adjustment potentiometer for fine adjustment.



OBD Tachometer

OBD Tachometer

Provides the end user and repair technician access to the OBD warning system right from the tachometer. No additional switches or lights required.

The OBD or On-board diagnostics system is the notification system on some engines that reports "health of the system" or warning light indications of faults in engine operation. The malfunction indicator light (MIL) lets the user know if there is a fault in the engine.

The OBD tachometer is the easiest way of providing OBD warning indication with the end user. There are no special connections that need to be made between the OBD system and tachometer. Just connect up the OBD leads to the tachometer and you are done.

Warning Light Tachometer

Warning Light Tachometer

Warning lights for Check Engine, Temperature, Oil Level and Rev Limit or for No Oil, Engine Overheat, Check Engine and Low Oil.



Monitor Tachometer

4 and 5 inch sizes with multiple ranges;

- 6000 RPM for Inboard and I/O engines
- 7000 RPM for all Outboard engines
- 3000 - 5000 RPM for diesel engines

2 inch with ranges from

- 1500 RPM to 4000 RPM

Available in all Faria styles.

Faria Beede offers a wide range of Analog instruments

Available in a wide variety of styles and configurations.



Digital Stepper Motor instruments



- Direct Replacement for Analog Gauges
- Stepper Motor Driven gauges for increased Accuracy and Gauge Life.
- Uses Analog inputs
- Can be configured for any Analog configuration.

Senders, Sensors and Switches

Pressure Switches



Temperature Senders



Adjustable Fuel Level Senders



Pressure Senders



Temp. Sender/Switch



(For Tanks 6 to 25" deep)



Remote Asset Monitoring



HMI Digital Screens



Glass Dashboard Solutions

Send information with
No Additional Costly Monthly fees



← **OEM** →
Customized Applications



Fleet Management
GPS Location
Individual Asset Monitoring

Custom Web Apps
World Wide Solutions

WD100
Wi-Fi CANBus
Communication
Module



WD500
Cellular Asset
and Tracking
with Engine Monitoring



TPM System
Tire Pressure Management

WD750
Satellite/Cellular Asset
and Tracking
with Engine Monitoring



WD310
GPS Location



WD300
Cellular Asset
Monitoring and
Tracking



LONEWorker
Man Down™ system



Active RF ID Tag
Asset Tracking system

SAE J1939
SAE J1708



ModBus
CANopen



Advanced Telematics Solutions

Faria Beede EntelNet™ Telematics system is a cellular, wi-fi and satellite-based asset location tracking, monitoring, diagnostic, emergency notification and communication system.

Faria Beede's communication networks includes an extensive network of low-earth-orbit satellites and cellular carriers to provide worldwide coverage and ensure that your connections are not only reliable, but affordable too.

Universal M150L20 Series Control Panel



The M150L Series Control Panels are a universal platform of products designed to control J1939 electronically governed engines. With a family of panel configurations ranging from panel mount to single gauge to multi-gauge and a NEMA 4X enclosure virtually any installation can be met. If a panel or enclosure is not required the M150L series offers a kit containing all necessary parts that can be mounted in a customer specific panel design.

With a full featured J1939 interface the M150L series panels provide a complete interface for virtually any SAE J1939 data. With standard features such as "TSC1 Throttle Control", "Fuel Level Input", "Engine Oil Pressure" and "Engine Shutdown", the M150L provides the most features in the price range.

Using the traditional look of a round gauge and the latest microprocessor technology the M150L series products provide the user with a traditional "look and feel" for controlling the latest electronic engines. Incorporating the latest technology allows the M150L products to be fully scalable from a single gauge solution to a full feature multi-gauge applications.

Universal M150L15 Series Control Panel



With a full featured J1939 interface the M150L15 series panels provide a complete interface for virtually any SAE J1939 data. With standard features such as "TSC1 Throttle Control", "Fuel Level Input", "Engine Oil Pressure" and "Engine Shutdown", the M150L provides the most features in the price range. The gateway interface is available in a 4" or 5" configuration. The M150L15 configuration can be shipped with variety of gauge configurations including: oil pressure, engine temperature, voltage and fuel expansion gauges.

Using the traditional look of a round gauge and the latest microprocessor technology the M150L15 series products provide the user with a traditional "look and feel" for controlling the latest electronic engines. Incorporating the latest technology allows the M150L products to be fully scalable from a single gauge solution to a full feature multi-gauge applications.

- Analog Input for Fuel Level
- Analog Input for Engine Oil Pressure
- User configurable engine speed limits
- Programmable throttle operation
- Engine Maintenance Interval
- SAE J1939 compatible throttle control
- SAE J1939 compatible Diagnostics
- RGB LED back-lighting multi-color display lighting
- Multi Language Support
- Remote Engine Shutdown
- Audible and Visual Alarms

Universal M150L Series Control Instruments

The M150L Series Control Kits are designed to provide Plug N' Play solutions for installations with existing panel designs and are featured in our L15 and L20 Engine Control panels. These kits are designed to control J1939 electronically governed engines.

With a full featured J1939 interface the L00 series kits provide a complete interface for virtually any SAE J1939 data. With standard features such as "TSC1 Throttle Control", "Fuel Level Input", "Engine Oil Pressure" and "Engine Shutdown", the L00 series kits provide the most features in the price range.

With the traditional look of a round gauge using the latest microprocessor technology the M150L series products provide the user with a traditional "look and feel" for controlling the latest electronic engines. Incorporating the latest technology allows the M150L products to be fully scalable from a single gauge solution to a full feature multi-gauge applications.



Oil Pressure

Water Temp



Voltmeter

Fuel Level



Throttle Control



Key Switch



Harness



Made in the USA

An ISO9001:2008 Registered Company

Manufactured by the Faria Beede Instruments, Inc. , Uncasville CT, USA • Copyright and all other rights reserved.
Our products are continually being improved. Specifications may change without notice.



Faria Beede Instruments, Inc.
P. O. Box 983
Uncasville, CT 06382
860.848.9271
Fax: 860.848.2704

fm-002-0015 rev 17012401